

CBSE Board
Class X Summative Assessment – II
Mathematics
Board Question Paper 2014 – Set 2

Time: 3 hrs

Max. Marks: 90

Note:

- Please check that this question paper contains 15 printed pages.
- Code number given on the right hand side of the question paper should be written on the title page of the answer-book by the candidate.
- Please check that this question paper contains 34 questions.
- Please write down the Serial Number of the question before attempting it.
- 15 minutes time has been allotted to read this question paper..The question paper will be distributed at 10.15 a.m. From 10.15 a.m. to 10.30 a.m., the students will read the question paper only and will not write any answer on the answer-book during this period.

General Instructions:

- (i) All questions are compulsory.
- (ii) The question paper consists of 34 questions divided into four sections -A, B, C and D.
- (iii) Section A contains 8 questions of 1 mark each, which are multiple choice type questions, Section B contains 6 questions of 2 marks each, Section C contains 10 questions of 3 marks each and Section D contains 10 questions of 4 marks each.
- (iv) Use of calculators is not permitted.

SECTION A

Question numbers 1 to 8 carry 1 mark each. For each of the question numbers 1 to 8, four alternative choices have been provided, of which only one is correct. Select the correct choice.

1. The probability that a number selected at random from the numbers 1, 2, 3, ..., 15 is a multiple of 4, is

(A) $\frac{4}{15}$

(B) $\frac{2}{15}$

(C) $\frac{1}{5}$

(D) $\frac{1}{3}$

2. The angle of depression of a car parked on the road from the top of a 150 m high tower is 30° . The distance of the car from the tower (in metres) is
- (A) $50\sqrt{3}$
- (B) $150\sqrt{3}$
- (C) $150\sqrt{2}$
- (D) 75
3. Two circles touch each other externally at P. AB is a common tangent to the circles touching them at A and B. The value of $\angle APB$ is
- (A) 30°
- (B) 45°
- (C) 60°
- (D) 90°
4. If k , $2k - 1$ and $2k + 1$ are three consecutive terms of an A.P., the value of k is
- (A) 2
- (B) 3
- (C) -3
- (D) 5
5. A chord of a circle of radius 10 cm subtends a right angle at its centre. The length of the chord (in cm) is
- (A) $5\sqrt{2}$
- (B) $10\sqrt{2}$
- (C) $\frac{5}{\sqrt{2}}$
- (D) $10\sqrt{3}$

6. ABCD is a rectangle whose three vertices are B (4, 0), C(4, 3) and D(4, 3). The length of one of its diagonals is
(A) 5
(B) 4
(C) 3
(D) 25
7. In a right triangle ABC, right-angled at B, BC = 12 cm and AB = 5 cm. The radius of the circle inscribed in the triangle (in cm) is
(A) 4
(B) 3
(C) 2
(D) 1
8. In a family of 3 children, the probability of having at least one boy is
(A) $\frac{7}{8}$
(B) $\frac{1}{8}$
(C) $\frac{5}{8}$
(D) $\frac{3}{4}$

SECTION B

Question numbers 9 to 14 carry 2 marks each.

9. In Figure 1, common tangents AB and CD to the two circles with centres O_1 and O_2 intersect at E. Prove that $AB = CD$.

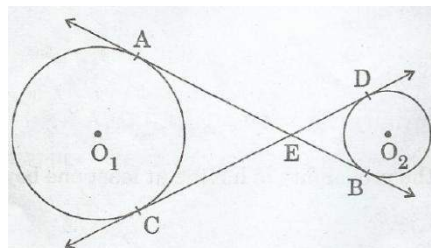

Figure 1

10. The incircle of an isosceles triangle ABC, in which $AB = AC$, touches the sides BC, CA and AB at D, E and F respectively. Prove that $BD = DC$.
11. Two different dice are tossed together. Find the probability
(i) that the number on each die is even.
(ii) that the sum of numbers appearing on the two dice is 5.
12. If the total surface area of a solid hemisphere is 462 cm^2 , find its volume.
[Take $\pi = \frac{22}{7}$]
13. Find the number of natural numbers between 101 and 999 which are divisible by both 2 and 5.
14. Find the values of k for which the quadratic equation $9x^2 - 3kx + k = 0$ has equal roots.

SECTION C

Question numbers 15 to 24 carry 3 marks each.

15. The angle of elevation of an aeroplane from a point on the ground is 60° . After a flight of 30 seconds the angle of elevation becomes 30° . If the aeroplane is flying at a constant height of $3000\sqrt{3}$ m, find the speed of the aeroplane.
16. The largest possible sphere is carved out of a wooden solid cube of side 7 cm. Find the volume of the wood left. [Use $\pi = \frac{22}{7}$]
17. Water in a canal, 6 m wide and 1.5 m deep, is flowing at a speed of 4 km/h. How much area will it irrigate in 10 minutes, if 8 cm of standing water is needed for irrigation?
18. In Figure 2, ABCD is a trapezium of area 24.5 sq. cm. In it, $AD \parallel BC$, $\angle DAB = 90^\circ$, $AD = 10$ cm and $BC = 4$ cm. If ABE is a quadrant of a circle, find the area of the shaded region. [Take $\pi = \frac{22}{7}$]

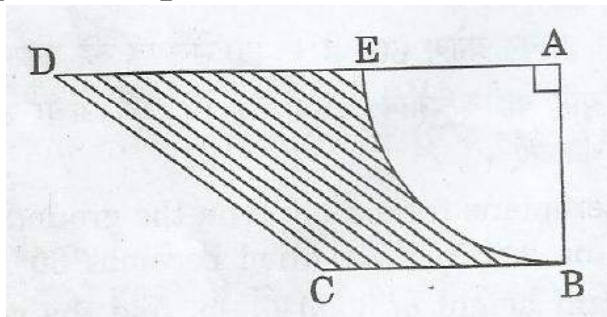

19. Find the ratio in which the line segment joining the points A(3,- 3) and B(- 2, 7) is divided by x-axis. Also find the coordinates of the point of division.
20. In Figure 3, two concentric circles with centre O, have radii 21cm and 42 em. If $\angle AOB = 60^\circ$, find the area of the shaded region. $\left[\text{Use } \pi = \frac{22}{7} \right]$

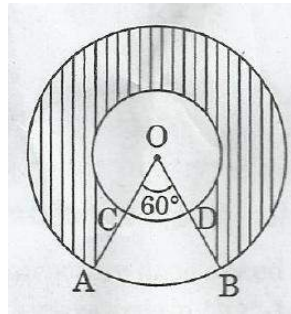

21. Solve for x:
$$\frac{16}{x} - 1 = \frac{15}{x+1}; \quad x \neq 0, -1$$
22. The sum of the 2nd and the 7th terms of an AP is 30. If its 15th term is 1 less than twice its 8th term, find the AP.
23. Draw a line segment AB of length 8 cm. Taking A as centre, draw a circle of radius 4 em and taking B as centre, draw another circle of radius 3 cm. Construct tangents to each circle from the centre of the other circle.
24. Prove that the diagonals of a rectangle ABCD, with vertices A(2, -1), B(5, -1), C(5, 6) and D(2, 6), are equal and bisect each other.

SECTION D

Question numbers 25 to 34 carry 4 marks each.

25. Prove that the tangent at any point of a circle is perpendicular to the radius through the point of contact.
26. 150 spherical marbles, each of diameter 1.4 cm, are dropped in a cylindrical vessel of diameter 7 cm containing some water, which are completely immersed in water. Find the rise in the level of water in the vessel.
27. A container open at the top, is in the form of a frustum of a cone of height 24 cm with radii of its lower and upper circular ends, as 8 cm and 20 cm respectively. Find the cost of milk which can completely fill the container. at the rate of 21 per litre.
 $\left[\text{Use } \pi = \frac{22}{7} \right]$

28. The angle of elevation of the top of a tower at a distance of 120 m from a point A on the ground is 45° . If the angle of elevation of the top of a flagstaff fixed at the top of the tower, at A is 60° , then find the height of the flagstaff. [Use $\sqrt{3} = 1.73$]
29. A motorboat whose speed in still water is 18 km/h, takes 1 hour more to go 24 km upstream than to return downstream to the same spot. Find the speed of the stream.
30. In a school, students decided to plant trees in and around the school to reduce air pollution. It was decided that the number of trees, that each section of each class will plant, will be double of the class in which they are studying. If there are 1 to 12 classes in the school and each class has two sections, find how many trees were planted by the students. Which value is shown in this question?
31. Solve for x:
$$\frac{x-3}{x-4} + \frac{x-5}{x-6} = \frac{10}{3}; x \neq 4, 6$$
32. All the red face cards are removed from a pack of 52 playing cards. A card is drawn at random from the remaining cards, after reshuffling them. Find the probability that the drawn card is
- (i) of red colour
 - (ii) a queen
 - (iii) an ace
 - (iv) a face card
33. A(4, - 6), B(3, - 2) and C(5, 2) are the vertices of a $\triangle ABC$ and AD is its median. Prove that the median AD divides $\triangle ABC$ into two triangles of equal areas.
34. Prove that opposite sides of a quadrilateral circumscribing a circle subtend supplementary angles at the centre of the circle.

CBSE Board
Class X Summative Assessment - II
Mathematics
Board Question Paper 2014 - Set 2

Time: 3 hrs

Max. Marks: 90

Solution
Section A

1. Correct answer: C
The multiples of 4 between 1 and 15 are 4, 8 and 12. The probability of getting a multiple of 4 = $\frac{3}{15} = \frac{1}{5}$
2. Correct answer: A

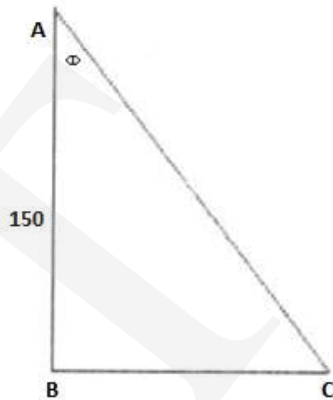

Let AB be the tower and BC be distance between tower and car. Let θ be the angle of depression of the car.

According to the given information,

In $\triangle ABC$,

$$\tan \theta = \frac{BC}{AB} \quad [\text{Using (1)}] \text{ and } \tan 30^\circ = \frac{1}{\sqrt{3}}$$

$$\therefore BC = \frac{150}{\sqrt{3}} = \frac{150\sqrt{3}}{3} = 50\sqrt{3}$$

Hence, distance between the tower and car is $50\sqrt{3}$.

3. Correct answer: D

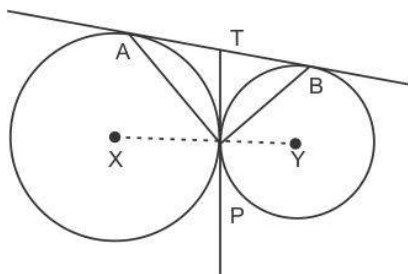

$$TA = TP \Rightarrow \angle TAP = \angle TPA$$

$$TB = TP \Rightarrow \angle TBP = \angle TPB$$

$$\therefore \angle TAP + \angle TBP = \angle TPA + \angle TPB = \angle APB$$

$$\underline{\angle TAP + \angle TBP} + \angle APB = 180^\circ \quad [\because \text{sum of } \dots 180^\circ]$$

$$\therefore \angle APB + \angle APB = 180^\circ$$

$$\therefore 2\angle APB = 180^\circ$$

$$\therefore \angle APB = 90^\circ$$

4. Correct answer: B

$k, 2k - 1, 2k + 1$ are in Arithmetic Progression
if a_1, a_2 and a_3 are in A.P. then

$$a_2 - a_1 = a_3 - a_2$$

$$2a_2 = a_3 + a_1$$

$$2 \times (2k - 1) = (2k + 1) + k$$

$$4k - 2 = 3k + 1$$

$$k = 3$$

5. Correct answer: B

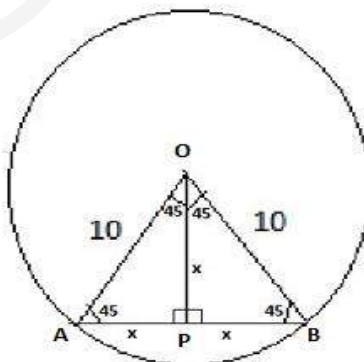

Given $\angle AOB$ is given as 90°

$\triangle AOB$ is an isosceles triangle since $OA = OB$

Therefore $\angle OAB = \angle OBA = 45^\circ$

Thus $\angle AOP = 45^\circ$ and $\angle BOP = 45^\circ$

Hence $\triangle AOP$ and $\triangle BOP$ also are isosceles triangles

$\therefore AP = OP$ and $OP = PB$

Let $AP = OP = PB = x$

In $\triangle AOP$

$$x^2 + x^2 = 10^2 \text{ [Pythagoras theorem]}$$

$$\text{Thus } 2x^2 = 100$$

$$x = 5\sqrt{2}$$

$$\text{Hence length of chord } AB = 2x = 5\sqrt{2} + 5\sqrt{2} = 10\sqrt{2}$$

6. Correct answer: A

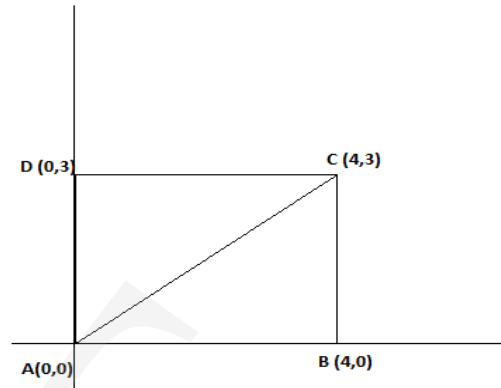

We see that $AB = 4$ units and $BC = 3$ units

Using Pythagoras theorem

$$AC^2 = AB^2 + BC^2$$

$$= 4^2 + 3^2$$

$$AC^2 = 25$$

Thus $AC = 5$ units

Hence length of the diagonal of the rectangle is 5 units

7. Correct answer: C

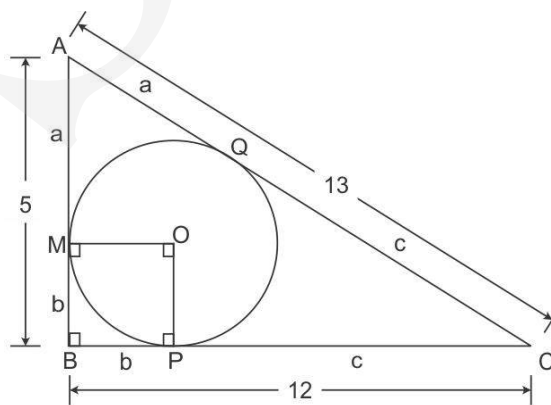

It is given that $AB = 5$ and $BC = 12$

Using Pythagoras theorem

$$AC^2 = AB^2 + BC^2$$

$$= 5^2 + 12^2$$

$$= 169$$

Thus $AC = 13$

We know that two tangents drawn to a circle from the same point that is exterior to the circle are of equal lengths.

Thus $AM = AQ = a$

Similarly $MB = BP = b$ and $PC = CQ = c$

We know

$$AB = a + b = 5$$

$$BC = b + c = 12 \text{ and}$$

$$AC = a + c = 13$$

Solving simultaneously we get $a=3$, $b=2$ and $c=10$

We also know that the tangent is perpendicular to the radius

Thus $OMBP$ is a square with side b

Hence the length of the radius of the circle inscribed in the right angled triangle is 2 cm.

8. Correct answer: A

There are in all $2^3 = 8$ combinations or outcomes for the gender of the 3 children

The eight combinations are as follows

BBB, BBG, BGB, BGG, GBB, GBG, GGB, GGG

Thus the probability of having at least one boy in a family is $\frac{7}{8}$

SECTION B

9. Solution:

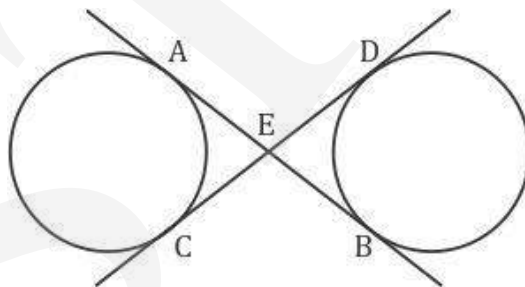

Given: AB and CD are common tangents to both the circles.

To prove: $AB = CD$

Proof:

We know that two tangents drawn to a circle for the same exterior point are equal.

Thus we get

$$AE = EC \quad (i)$$

Similarly

$$ED = EB \quad (ii)$$

$$AB = AE + EB \quad (iii)$$

and

$$CD = CE + ED \quad (iv)$$

$$AB = EC + EB \quad \text{from (i) and (iii)}$$

$$CD = EC + EB \quad \text{from (ii) and (iv)}$$

Therefore $AB = CD$

Hence proved.

10.

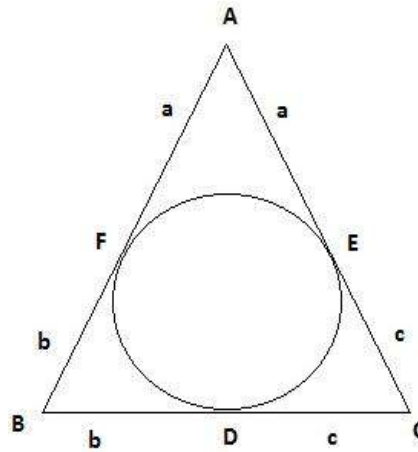

Given: $\triangle ABC$ is an isosceles triangle in which $AB = AC$; with a circle inscribed in the triangle.

To prove: $BD = DC$

Proof:

AF and AE are tangents drawn to the circle from point A .

Since two tangents drawn to a circle from the same exterior point are equal,

$$AF = AE = a$$

Similarly $BF = BD = b$ and $CD = CE = c$

We also know that $\triangle ABC$ is an isosceles triangle in which $AB = AC$.

$$a + b = a + c$$

$$\text{Thus } b = c$$

Therefore, $BD = DC$

Hence proved.

11. Solution:

The total number of outcomes when two dice are tossed together is 36.

The sample space is as follows

	1	2	3	4	5	6
1	(1,1)	(1,2)	(1,3)	(1,4)	(1,5)	(1,6)
2	(2,1)	(2,2)	(2,3)	(2,4)	(2,5)	(2,6)
3	(3,1)	(3,2)	(3,3)	(3,4)	(3,5)	(3,6)
4	(4,1)	(4,2)	(4,3)	(4,4)	(4,5)	(4,6)
5	(5,1)	(5,2)	(5,3)	(5,4)	(5,5)	(5,6)
6	(6,1)	(6,2)	(6,3)	(6,4)	(6,5)	(6,6)

- i. Let E be the event 'that number of each die is even'
Favourable outcomes = { (2,2) , (2,4), (2,6), (4,2), (4,4), (4,6), (6,2), (6,4), (6,6) }

Probability that the number on each dice is even

$$P(E) = \frac{\text{Number of favourable outcomes}}{\text{Total number of outcomes}} = \frac{9}{36} = \frac{1}{4}$$

- ii. Let F be the event

- iii. Favourable outcomes = { (1,4) (2,3) (3,2) (4,1) }

Probability that the sum of the numbers appearing on the two dice is 5

$$= \frac{\text{Number of favourable outcomes}}{\text{Total number of outcomes}} = \frac{4}{36} = \frac{1}{9}$$

12. Solution:

Given total surface area of hemisphere = 462 cm²

$$2\pi r^2 = 462$$

$$r = 8.574\text{cm}$$

$$\text{Volume of a hemisphere} = \frac{2}{3}\pi r^3$$

$$\therefore \frac{2}{3}\pi r^3 = \frac{2}{3} \times \frac{22}{7} \times 8.574^3 = 1320.54$$

$$\Rightarrow r^3 = \frac{4851}{2} \times \frac{3}{2} \times \frac{7}{22} = \left(\frac{21}{2}\right)^3$$

13. Solution:

Numbers which are divisible by both 2 and 5 are the numbers which are divisible by 10.

Thus we need to find the number of natural numbers between 101 and 999 which are divisible by 10.

The first number between 101 and 999 which is divisible by 10 is 110

And the last number between 101 and 999 which is divisible by 10 is 990

Using the formula for arithmetic progression where first term (a) = 110, last term (T_n) = 990 and difference (d) = 10

$$T_n = a + (n-1)d$$

$$990 = 110 + (n-1)10$$

$$880 = (n-1)10$$

$$88 = n-1$$

$$n = 89$$

Hence there are 89 natural numbers between 101 and 999 which are divisible by both 2 and 5.

14. Solution:

Given: Quadratic equation $9x^2 - 3kx + k = 0$ has equal roots

Let β be the equal roots of the equation

$$\text{Thus } 2\beta = \frac{3k}{9} = \frac{k}{3} \quad (\text{Sum of the roots is equal to } -b/a)$$

$$\text{We get } \beta = \frac{k}{6} \quad (i)$$

$$\text{Or } \beta^2 = \frac{k^2}{36}$$

$$\text{Also, that } \beta^2 = \frac{k}{9} \quad (\text{Product of the roots is equal to } c/a) \quad (ii)$$

$$\frac{k^2}{36} = \frac{k}{9}$$

$$\text{For } k \neq 0, \frac{k}{36} = \frac{1}{9}$$

$$\text{Thus } k = 4$$

SECTION - C

15. Solution:

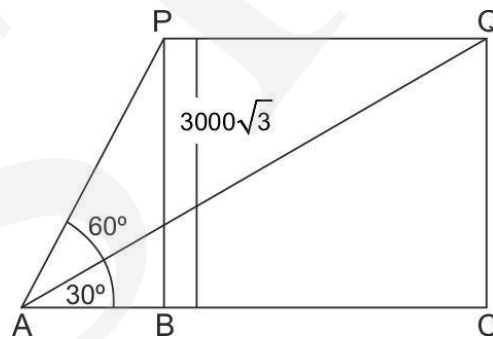

Let P and Q be the two positions of the plane and A be the point of observation. Let ABC be the horizontal line through A.

It is given that angles of elevation of the plane in two positions P and Q from a point A are 60° and 30° respectively.

$\therefore \angle PAB = 60^\circ, \angle QAB = 30^\circ$. It is also given that $PB = 3000\sqrt{3}$ meters

In $\triangle ABP$, we have

$$\tan 60 = \frac{BP}{AB}$$

$$\frac{\sqrt{3}}{1} = \frac{3000\sqrt{3}}{AB}$$

$$AB = 3000 \text{ m}$$

In $\triangle ACQ$, we have

$$\tan 30 = \frac{QC}{AC}$$

$$\frac{1}{\sqrt{3}} = \frac{3000\sqrt{3}}{AC}$$

$$AC = 9000 \text{ m}$$

$$\therefore \text{Distance} = BC = AC - AB = 9000\text{m} - 3000\text{m} = 6000\text{m}$$

Thus, the plane travels 6km in 30 seconds

$$\text{Hence speed of plane} = 6000/30 = 200 \text{ m/sec} = 720\text{km/h}$$

16. Solution:

Diameter of sphere curved out = side of cube = 7cm or Radius = 3.5cm

Volume of cube = a^3

$$= 7^3$$

$$= 343 \text{ cm}^3$$

Volume of sphere curved out = $\frac{4}{3} \pi r^3$

$$= \frac{4}{3} \times \frac{22}{7} \times \frac{7}{2} \times \frac{7}{2} \times \frac{7}{2} = 179.66 \text{ cm}^3$$

17. Solution:

Given:-

Speed of flowing water = 4km/h = $\frac{200}{3}$ metres per minute

Width of canal = 6 m and height of canal = 1.5 m

Standing water requirement for irrigation = 8 cm = 0.08 m

Cross section area of canal = width of canal * height of canal

$$= (6 * 1.5) \text{ m}^2$$

Volume of water needed to irrigate in 10 min = $10 \times 6 \times 1.5 \times \frac{200}{3} = 6000\text{m}^3$

Volume of water irrigated = base area (of irrigated land) x height

$$= \text{base area} \times 0.08\text{m}$$

$$6000 = \text{base area} \times 0.08$$

$$\text{Base area} = \frac{6000}{0.08} = 75000 \text{ m}^2$$

$$= 7.5 \text{ hectare}$$

$$[1 \text{ hectare} = 10000 \text{ m}^2]$$

$$\therefore \text{Sum} = \frac{n}{2} \{\text{first term} + \text{last term}\}$$

$$= \frac{128}{2} \{a_1 + a_{128}\}$$

$$= 64 \{105 + 994\} = (64)(1099) = 70336$$

18. Solution:

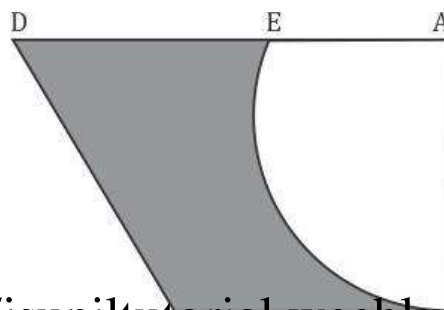

Given :-

$$AD = 10 \text{ cm}$$

$$BC = 4 \text{ cm}$$

$$\text{Area of trapezium} = 24.5 \text{ cm}^2$$

$$\text{Area of trapezium} = \frac{a+b}{2} \text{ height} \quad [\text{where 'a' and 'b' are parallel sides}]$$

$$= \frac{AD+BC}{2} AB$$

$$24.5 = \frac{10+4}{2} AB$$

$$\frac{24.5}{7} = AB$$

$$AB = 3.5 \text{ cm}$$

$$\text{Thus, radius} = 3.5 \text{ cm}$$

$$\text{Area of quadrant} = \text{Area of a circle} / 4$$

$$\text{Area of quadrant} = \frac{1}{4} * \pi * r^2 = 0.25 * \frac{22}{7} * 3.5 * 3.5 = 9.625 \text{ cm}^2$$

$$\text{The area of shaded region} = \text{Area of trapezium} - \text{Area of the given quadrant}$$

$$\text{The area of shaded region} = 24.5 - 9.625 = 14.875 \text{ cm}^2$$

19. Solution:

Point p lies on x axis so it's ordinate is 0 (Using section formula)

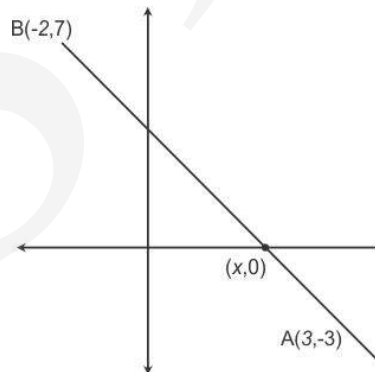

Let the ratio be k: 1 Let the coordinate of the point be P(x , 0)

As given A(3,-3) and B(-2,7)

The co-ordinates of the point P(x,y), which divide the line segment joining the points A(x₁,y₁) and B(x₂,y₂), internally in the ratio m₁:m₂ are

$$\left(\frac{mx_2 + nx_1}{m+n}, \frac{my_2 + ny_1}{m+n} \right)$$

$$P_y = \frac{my_2 + ny_1}{m+n}$$

Hence, A(3,-3) be the co-ordinates (x₁,y₁) and

B(-2,7) be the co-ordinates (x₂,y₂)

$$m = k$$

$$n = 1$$

$$0 = k \times 7 + 1 \times -3 / (k+1)$$

$$0(k+1) = 7k - 3$$

$$0 = 7k - 3$$

$$3 = 7k$$

$$k = 3 / 7$$

$$k:1 = 3 : 7$$

$$P_x = \frac{mx_2 + nx_1}{m+n}$$

$$P_x = \frac{\left[\left(\frac{3}{7} \times -2 \right) + (1 \times 3) \right]}{\left(\frac{3}{7} + 1 \right)} = 2.41$$

20. Solution:

Given :

Radii of inner circle = 21 cm = r

Radii of outer circle = 42 cm = R

$\angle AOB = \theta = 60^\circ$

Also,

Area of ring = $\pi (R^2 - r^2)$

Area of a sector = $\frac{\theta}{360} * \pi r^2$

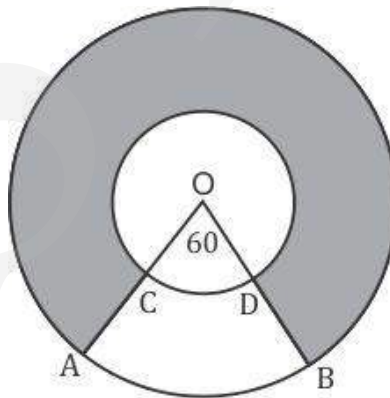

The area of shaded region = Area of ring - Area of ABCD

= Area of ring - Area of sector of Outer Circle - Area of sector of Inner Circle

$$= \pi(R^2 - r^2) - \frac{\pi(R^2 - r^2)}{1} \times \frac{\theta}{360}$$

$$= \pi(R^2 - r^2) - \frac{\pi(R^2 - r^2)}{1} \times \frac{\theta}{360}$$

$$= \pi(R^2 - r^2) \left[1 - \frac{\theta}{360} \right]$$

$$\text{http://jsuniltutorial.weebly.com/10}$$

$$= 3465 \text{ cm}^2$$

21. Solution:

$$\begin{aligned}\text{Given: } \frac{16}{x} - 1 &= \frac{15}{x+1}; \quad x \neq 0, -1 \\ \therefore \frac{16-x}{x} &= \frac{15}{x+1} \\ \frac{16-x}{x} &= \frac{15}{x+1} \\ \frac{(16-x)(x+1)}{1} &= \frac{15x}{1} \\ 16x + 16 - x^2 - x &= 15x \\ 16 &= x^2 \\ x &= 4\end{aligned}$$

22. Solution:

The sum of 2nd and the 7th terms of an AP is 30

$$(a + d) + (a + 6d) = 30$$

$$2a + 7d = 30 \quad \text{(i)}$$

Now,

15th term is 1 less than twice the 8th term

$$(a + 14d) = 2(a + 7d) - 1$$

$$a + 14d = 2a + 14d - 1$$

$$a = 1 \quad \text{(ii)}$$

Substituting the values in (i)

$$2 \times 1 + 7d = 30$$

$$d = 4 \quad \text{(iii)}$$

Hence, the terms in AP are a, a+d, a+2d, a+3d....

AP : 1, 5, 9

23. Solution:

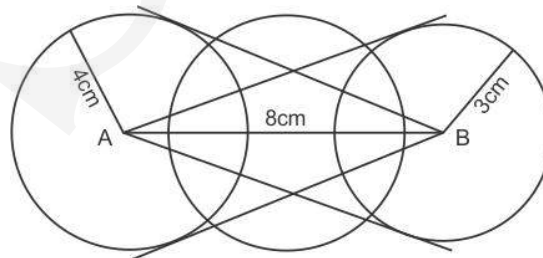

24. Solution: <http://jsuniltutorial.weebly.com/11>

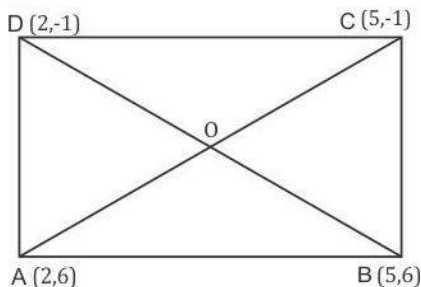

$\triangle ADC$ and $\triangle BDC$ are right angled triangles with AD and BC as hypotaneus

$$AC^2 = AB^2 + DC^2$$

$$AC^2 = (5-2)^2 + (6 + 1)^2 = 9 + 49 = 58 \text{ sq. unit}$$

$$BD^2 = DC^2 + CB^2$$

$$BD^2 = (5-2)^2 + (-1 - 6)^2 = 9 + 49 = 58 \text{ sq. unit}$$

Hence, both the diagonals are equal in length.

SECTION D

25. Solution:

Given: A circle C (O, r) and a tangent l at point A.

To prove: $OA \perp l$

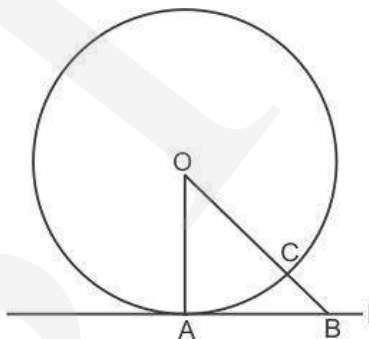

Construction: Take a point B, other than A, on the tangent l. Join OB.

Suppose OB meets the circle in C.

Proof: We know that, among all line segments joining the point O to a point on l, the perpendicular is shortest to l.

$OA = OC$ (Radius of the same circle)

But, $OB = OC + BC$.

$\therefore OB > OC$

$\Rightarrow OB > OA$

$\Rightarrow OA < OB$

This is true for all positions of B on l.

Thus, OA is the shortest distance between point A and line segment l.

Hence, $OA \perp l$

26. Solution:

Given:-

Diameter of cylindrical vessel = 7 cm

Diameter of spherical marbles = 1.4 cm

Volume of a sphere =

Volume of 1000 spherical marbles with diameter 1.4 cm = volume of cylindrical vessel of diameter 7 cm displaced

$$\text{Volume of a Sphere} = \frac{4}{3}\pi r^3$$

$$150 \times \frac{4}{3}\pi\left(\frac{1.4}{2}\right)^3 = \pi\left(\frac{7}{2}\right)^2 \times h$$

$$h = 5.6 \text{ cm}$$

27. Solution:

$$\text{Volume of a frustum of a cone} = \frac{1}{3}\pi h(r_1^2 + r_2^2 + r_1 \times r_2)$$

$$\begin{aligned}\text{Volume of container} &= \frac{1}{3}\pi \times h (R^2 + r^2 + Rr) \\ &= \frac{1}{3} \times 22/7 \times 24 [20 \times 20 + 8 \times 8 + 20 \times 8] \\ &= 15689.14 \text{ cm}^3 \\ &= 15.69 \text{ litre}\end{aligned}$$

The cost of milk which can completely fill the container at the rate of Rs.21 per liter = Rs(21 x 15.69) = 329.49

28. Solution:

Let AB is the tower of height h meter and AC is flagstaff of height x meter.

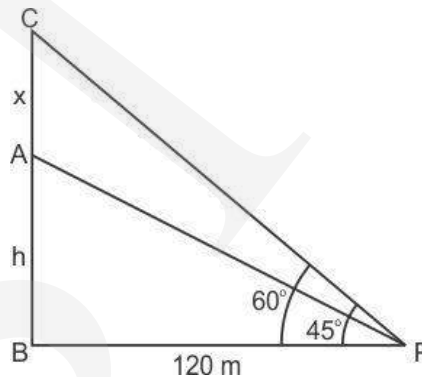

$$\angle APB = 45^\circ \text{ and } \angle BPC = 60^\circ$$

$$\tan 60 = (x+h)/120$$

$$\sqrt{3} = \frac{x+h}{120}$$

$$x = 120\sqrt{3} - h$$

$$\tan 45 = h/120$$

$$1 = h/120$$

$$h = 120$$

Therefore height of the flagstaff =

$$= 120\sqrt{3} - 120$$

$$= 120(\sqrt{3} - 1)$$

$$= 120 \times .73$$

$$= 87.6 \text{ m}$$

29. Solution: <http://jsuniltutorial.weebly.com/13>

Let speed of stream = x km/h

Speed of boat in still water = 18 km/h

Speed of boat in upstream = $(18 - x)$ km/h

Speed of boat in downstream = $(18 + x)$ km/h

Distance = 24 km

As per question, it takes 1 hour more to go upstream 24 km, than downstream

$$24 \text{ km} / (18 - x) = 24 \text{ km} / (18 + x) + 1$$

$$x^2 + 48x - 324 = 0$$

$$x = 6 \text{ or } x = -54$$

But, as speed can not be negative

Hence, the speed of stream = 6 km/h

30. Solution:

Class 1 plant trees = 2 x class 1 x 2 section = $2 \times 1 \times 2 = 4$ x class = $4 \times 1 = 4$ trees

Class 2 plant trees = 4 x class = $4 \times 2 = 8$ trees

$$a = 4$$

$$d = 8$$

$$n = 12$$

$$S_{12} = 12/2[2 \times 4 + 11 \times 8] = 312 \text{ trees}$$

31. Solution:

$$\frac{x-3}{x-4} + \frac{x-5}{x-6} = \frac{10}{3}$$

$$\frac{[(x-3)(x-6) + (x-4)(x-5)]}{(x-4)(x-6)} = \frac{10}{3}$$

$$\frac{x^2 - 9x + 18 + x^2 - 9x + 20}{(x-4)(x-6)} = \frac{10}{3}$$

$$\frac{2x^2 - 18x + 38}{(x-4)(x-6)} = \frac{10}{3}$$

$$\frac{2(x^2 - 9x + 19)}{1} = \frac{10}{3}(x^2 - 10x + 24)$$

$$\frac{x - 9x + 19}{1} = \frac{5}{3}[x^2 - 10x + 24]$$

$$3x^2 - 27x + 57 = 5x^2 - 50x + 120$$

$$2x^2 - 23x + 63 = 0$$

$$\therefore x = 7 \text{ or } x = \frac{9}{2}$$

32. Solution:

(i) face card are removed from a pack of 52 playing card = 6

Total favorable outcomes = $52 - 6 = 46$

Number of red color cards in the remaining pack = $26 - 6 = 20$

$P[E] = 20/46 = 10/23$

(ii) Number of queen cards in the remaining pack = 2

$P[E] = 2/46 = 1/23$

(iii) Number of aces in the remaining pack = 2

$P[E] = 2/46 = 1/23$

(iv) Number of face cards in the remaining pack = 6

$P[E] = 6/46 = 3/23$

33. Solution:

Let the co-ordinates of D be D (x,y) and D is midpoint of BC

$x = (3+5)/2 = 4$; $y = (2-2)/2 = 0$

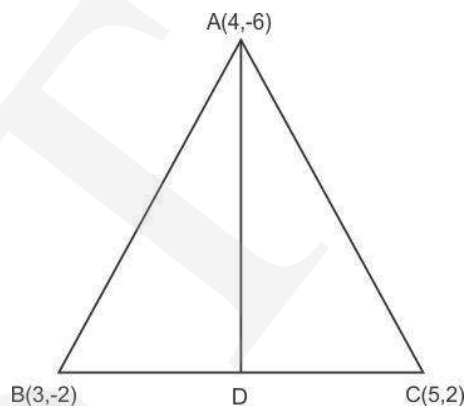

Now Area of triangle ABD = $\frac{1}{2} [4(-2-0) + 3(0+6) + 4(-6+2)] = 3$ sq unit

and Area of triangle ACD = $\frac{1}{2} [5(-6-0) + 4(0 - 2) + 4(2+6)] = 3$ sq unit

Hence, the median AD divides triangle ABC into two triangle of equal area.

34. Solution:

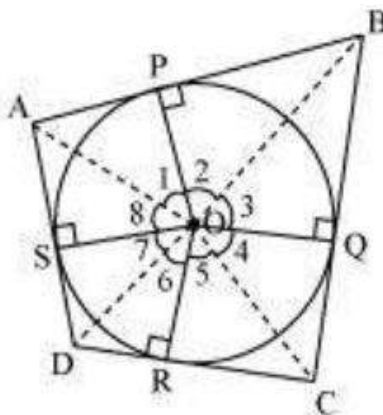

Let ABCD be a quadrilateral circumscribing a circle centered at O such that it touches the circle at point P, Q, R, S. Let us

join the vertices of the quadrilateral ABCD to the center O of the circle.

Consider $\triangle OAP$ and $\triangle OAS$,

$AP = AS$ (Tangents from the same point)

$OP = OS$ (Radii of the same circle)

$OA = OA$ (Common side)

Thus, by Side-Side-Side criterion of congruence, we have

$\triangle OAP \cong \triangle OAS$ (SSS congruence criterion)

Therefore, $\angle A \leftrightarrow \angle A$, $\angle P \leftrightarrow \angle S$, $\angle O \leftrightarrow \angle O$

The corresponding parts of the congruent triangles are congruent.

And thus, $\angle POA = \angle AOS$

$\angle 1 = \angle 8$

Similarly,

$\angle 2 = \angle 3$

$\angle 4 = \angle 5$

$\angle 6 = \angle 7$

$\angle 1 + \angle 2 + \angle 3 + \angle 4 + \angle 5 + \angle 6 + \angle 7 + \angle 8 = 360^\circ$

$(\angle 1 + \angle 8) + (\angle 2 + \angle 3) + (\angle 4 + \angle 5) + (\angle 6 + \angle 7) = 360^\circ$

$2\angle 1 + 2\angle 2 + 2\angle 5 + 2\angle 6 = 360^\circ$

$2(\angle 1 + \angle 2) + 2(\angle 5 + \angle 6) = 360^\circ$

$(\angle 1 + \angle 2) + (\angle 5 + \angle 6) = 180^\circ$

$\angle AOB + \angle COD = 180^\circ$

Similarly, we can prove that $\angle BOC + \angle DOA = 180^\circ$

Hence, opposite sides of a quadrilateral circumscribing a circle subtend supplementary angles at the centre of the circle.