

**CBSE Board
Class X Mathematics
Board Paper - 2013**

Time: 3 hour

Total Marks: 90

General Instructions:

1. All questions are **compulsory**.
 2. The question paper consists of **34** questions divided into **four sections** A, B, C, and D.
 3. **Section A** contains of **8** questions of 1 mark each, which are multiple choice type question, **Section B** contains of **6** questions of 2 marks each, **Section C** contains of **10** questions of 3 marks each and **Section D** contains of **10** questions of 4 marks each.
 4. Use of calculator is **not** permitted.
-

SECTION – A

1. The angle of depression of a car, standing on the ground, from the top of a 75 m high tower, is 30° . The distance of the car from the base of the tower (in m.) is:
(A) $25\sqrt{3}$
(B) $50\sqrt{3}$
(C) $75\sqrt{3}$
(D) 150
2. The probability of getting an even number, when a die is thrown once, is:
(A) $\frac{1}{2}$
(B) $\frac{1}{3}$
(C) $\frac{1}{6}$
(D) $\frac{5}{6}$

3. A box contains 90 discs, numbered from 1 to 90. If one disc is drawn at random from the box, the probability that it bears a prime-number less than 23, is:

(A) $\frac{7}{90}$

(B) $\frac{10}{90}$

(C) $\frac{4}{45}$

(D) $\frac{9}{89}$

4. In fig., a circle with centre O is inscribed in a quadrilateral ABCD such that, it touches the sides BC, AB, AD and CD at points P, Q, R and S respectively, If $AB = 29$ cm, $AD = 23$ cm, $\angle B = 90^\circ$ and $DS = 5$ cm, then the radius of the circle (in cm) is:

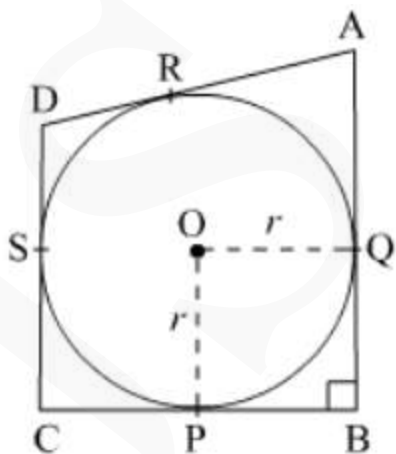

(A) 11

(B) 18

(C) 6

(D) 15

5. In fig., PA and PB are two tangents drawn from an external point P to a circle with centre C and radius 4 cm. If $PA \perp PB$, then the length of each tangent is:

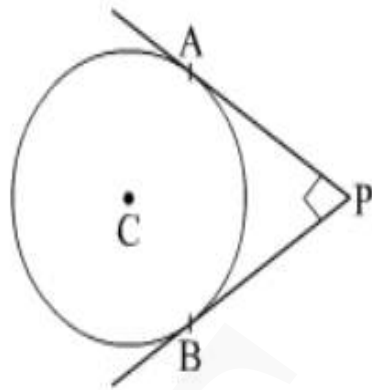

- (A) 3cm
- (B) 4cm
- (C) 5cm
- (D) 6cm

6. In fig., the area of triangle ABC (in sq. units) is:

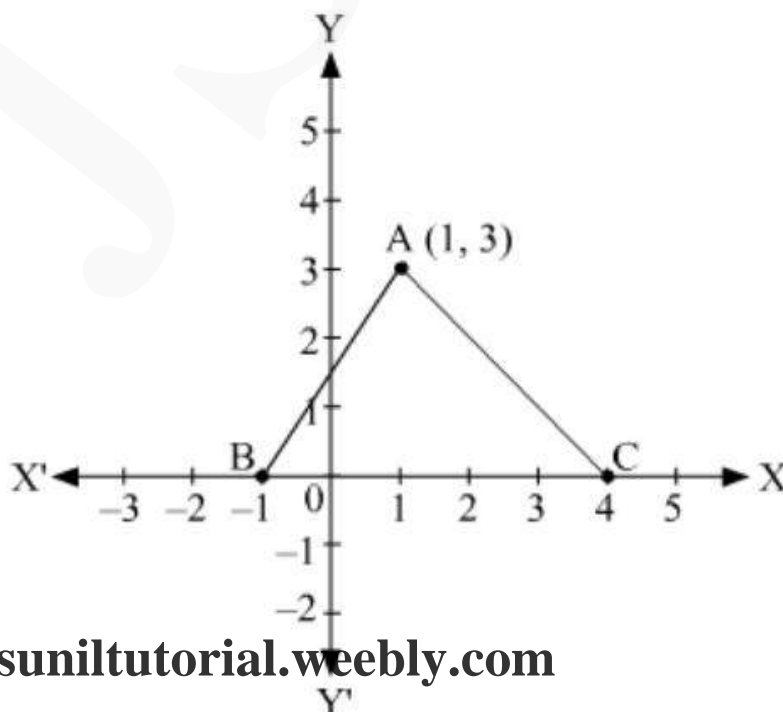

- (A) 15
- (B) 10
- (C) 7.5
- (D) 2.5

7. If the difference between the circumference and the radius of a circle is 37 cm, then using $\pi = \frac{22}{7}$, the circumference (in cm) of the circle is:

- (A) 154
- (B) 44
- (C) 14
- (D) 7

8. The common difference of AP $\frac{1}{3q}, \frac{1-6q}{3q}, \frac{1-12q}{3q}, \dots$ is:

- (A) q
- (B) -q
- (C) -2
- (D) 2

SECTION B

9. Prove that the parallelogram circumscribing a circle is a rhombus.
10. Two circular pieces of equal radii and maximum area, touching each other are cut out from a rectangular card board of dimensions 14 cm \times 7 cm. Find the area of the remaining card board. $\left[\text{Use } \pi = \frac{22}{7} \right]$
11. In fig., a circle is inscribed in triangle ABC touches its sides AB, BC and AC at points D, E and F respectively. If AB = 12 cm, BC = 8 cm and AC = 10 cm, then find the length of AD, BE and CF.

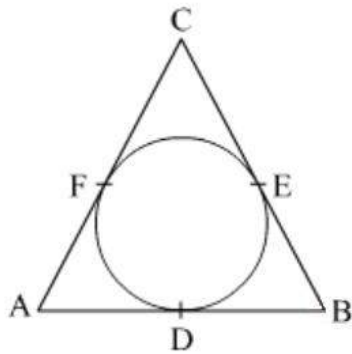

12. How many three-digit natural numbers are divisible by 7?

13. Solve the following quadratic equation for x:

$$4\sqrt{3}x^2 + 5x - 2\sqrt{3} = 0$$

14. A card is drawn at random from a well shuffled pack of 52 playing cards. Find the probability that the drawn card is neither a king nor a queen.

SECTION C

15. A vessel is in the form of hemispherical bowl surmounted by a hollow cylinder of same diameter. The diameter of the hemispherical bowl is 14 cm and the total height of the vessel is 13 cm. Find the total surface area of the vessel.

$$\left[\text{Use } \pi = \frac{22}{7} \right]$$

16. A wooden toy was made by scooping out a hemisphere of same radius from each end of a solid cylinder. If the height of the cylinder is 10 cm, and its base is of radius 3.5 cm, find the volume of wood in the toy. $\left[\text{Use } \pi = \frac{22}{7} \right]$

17. In a circle of radius 21 cm, an arc subtends an angle of 60° at the centre. Find: (i) the length of the arc (ii) area of the sector formed by the arc.

$$\left[\text{Use } \pi = \frac{22}{7} \right]$$

18. In Fig., AB and CD are two diameters of a circle with centre O, which are perpendicular to each other. OB is the diameter of the smaller circle. If OA = 7 cm, find the area of the shaded region. [Use $\pi = \frac{22}{7}$]

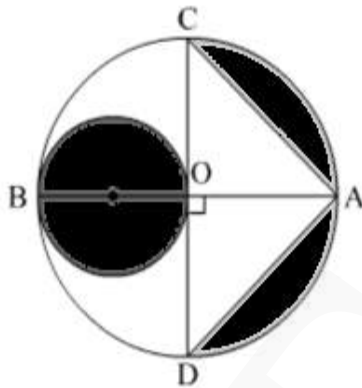

19. Find the ratio in which the y-axis divides the line segment joining the points (-4, -6) and (10, 12). Also, find the coordinates of the point of division.
20. The horizontal distance between two poles is 15 m. The angle of depression of the top of first pole as seen from the top of second pole is 30° . If the height of the second pole is 24 m, find the height of the first pole. [Use $\sqrt{3} = 1.732$]
21. For what values of k, the roots of the quadratic equation $(k + 4)x^2 + (k + 1)x + 1 = 0$ are equal?
22. The sum of first n terms of an AP is $3n^2 + 4n$. Find the 25th term of this AP.
23. Construct a tangent of a circle of radius 4 cm from a point on the concentric circle of radius 6 cm.
24. Show that the points (-2, 3), (8, 3) and (6, 7) are the vertices of a right triangle.

SECTION D

25. Water is flowing through a cylindrical pipe, of internal diameter 2 cm, into a cylindrical tank of base radius 40 cm, at the rate of 0.4 m/s. Determine the rise in level of water in the tank in half an hour.
26. A Group consists of 12 persons, of which 3 are extremely patient, other 6 are extremely honest and rest are extremely kind. A person from the group is selected at random. Assuming that each person is equally likely to be selected, find the probability of selecting a person who is (i) extremely patient (ii) extremely kind or honest. Which of the above values you prefer more?
27. A bucket open at the top, and made up of a metal sheet is in the form of a frustum of a cone. The depth of the bucket is 24 cm and the diameters of its upper and lower circular ends are 30 cm and 10 cm respectively. Find the cost of metal sheet used in it at the rate of Rs 10 per 100 cm². [Use $\pi = 3.14$]

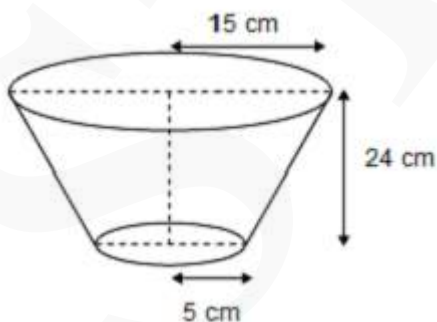

28. In fig., l and m are two parallel tangents to a circle with centre O , touching the circle at A and B respectively. Another tangent at C intersects the line l at D and m at E . Prove that $\angle DOE = 90^\circ$

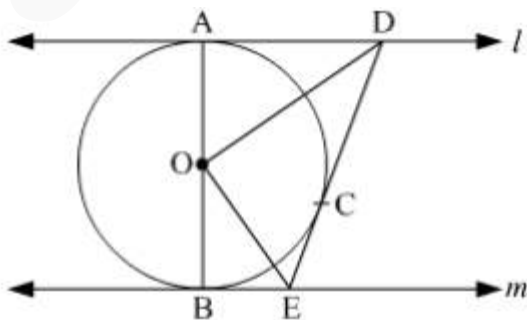

30. Solve the following for x :

$$\frac{1}{2a + b + 2x} = \frac{1}{2a} + \frac{1}{b} + \frac{1}{2x}$$

31. Prove that the tangent at any point of a circle is perpendicular to the radius through the point of contact.

32. Find the number of terms of the AP $-12, -9, -6, \dots, 12$. If 1 is added to each term of this AP, then find the sum of all terms of the AP thus obtained.

33. Two poles of equal heights are standing opposite each other on either side of the road, which is 80 m wide. From a point between them on the road, the angles of elevation of the top of the poles are 60° and 30° respectively. Find the height of the poles and the distances of the point from the poles.

34. If the area of triangle ABC formed by $A(x, y)$, $B(1, 2)$ and $C(2, 1)$ is 6 square units, then prove that $x + y = 15$.

**CBSE Board
Class X Mathematics
Board Paper - 2013**

Time: 3 hour

Total Marks: 90

**Solution
Section A**

1. Correct answer: C

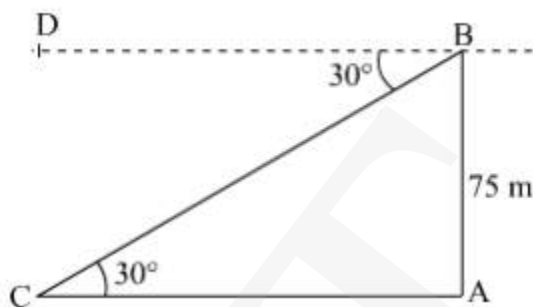

Let AB be the tower of height 75 m and C be the position of the car.

In $\triangle ABC$,

$$\cot 30^\circ = \frac{AC}{AB}$$

$$\Rightarrow AC = AB \cot 30^\circ$$

$$\Rightarrow AC = 75\text{m} \times \sqrt{3}$$

$$\Rightarrow AC = 75\sqrt{3}\text{m}$$

Thus, the distance of the car from the base of the tower is $75\sqrt{3}$ m.

2. Correct answer: A

$$S = \{1,2,3,4,5,6\}$$

Let event E be defined as 'getting an even number'.

$$n(E) = \{1,4,6\}$$

$$\therefore P E = \frac{\text{Number of favourable outcomes}}{\text{Number of possible outcomes}} = \frac{3}{6} = \frac{1}{2}$$

3. Correct answer: C

$$S = \{1, 2, 3, \dots, 90\}$$

$$n(S) = 90$$

The prime number less than 23 are 2, 3, 5, 7, 11, 13, 17, and 19.

Let event E be defined as 'getting a prime number less than 23'.

$$n(E) = 8$$

$$\therefore P E = \frac{\text{Number of favourable outcomes}}{\text{Number of possible outcomes}} = \frac{8}{90} = \frac{4}{45}$$

4. Correct answer: A

Given: AB, BC, CD and AD are tangents to the circle with centre O at Q, P, S and R respectively.

$$AB = 29 \text{ cm}, AD = 23, DS = 5 \text{ cm and } \angle B = 90^\circ$$

Construction: Join PQ.

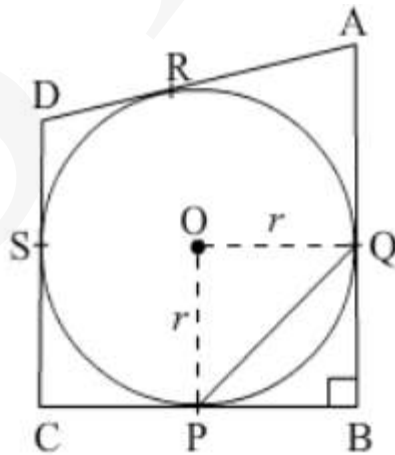

We know that, the lengths of the tangents drawn from an external point to a circle are equal.

$$DS = DR = 5 \text{ cm}$$

$$\therefore AR = AD - DR = 23 \text{ cm} - 5 \text{ cm} = 18 \text{ cm}$$

$$AQ = AR = 18 \text{ cm}$$

$$\therefore QB = AB - AQ = 29 \text{ cm} - 18 \text{ cm} = 11 \text{ cm}$$

$$QB = BP = 11 \text{ cm}$$

In $\triangle PQB$,

$$PQ^2 = QB^2 + BP^2 = (11 \text{ cm})^2 + (11 \text{ cm})^2 = 2 \times (11 \text{ cm})^2$$

$$PQ = 11\sqrt{2} \text{ cm} \quad \dots (1)$$

In $\triangle OPQ$,

$$PQ^2 = OQ^2 + OP^2 = r^2 + r^2 = 2r^2$$

$$(11\sqrt{2})^2 = 2r^2$$

$$121 = r^2$$

$$r = 11$$

Thus, the radius of the circle is 11 cm.

5. Correct answer: B

$AP \perp PB$ (Given)

$CA \perp AP, CB \perp BP$ (Since radius is perpendicular to tangent)

$AC = CB =$ radius of the circle

Therefore, $APBC$ is a square having side equal to 4 cm.

Therefore, length of each tangent is 4 cm.

6. Correct answer: C

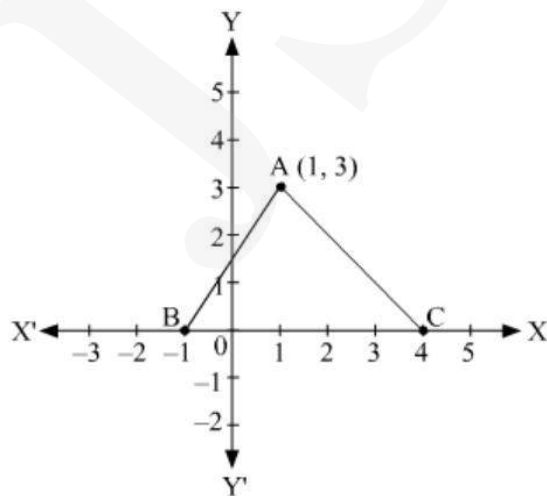

From the figure, the coordinates of A, B, and C are (1, 3), (-1, 0) and (4, 0)

respectively.

Area of $\triangle ABC$

$$\begin{aligned} &= \frac{1}{2} |1(0 - 0) + (-1)(0 - 3) + 4(3 - 0)| \\ &= \frac{1}{2} |0 + 3 + 12| \\ &= \frac{1}{2} |15| \\ &= 7.5 \text{ sq units} \end{aligned}$$

7. Correct answer: B

Let r be the radius of the circle.

From the given information, we have:

$$2\pi r - r = 37 \text{ cm}$$

$$\Rightarrow r(2\pi - 1) = 37 \text{ cm}$$

$$\Rightarrow r \left(2 \times \frac{22}{7} - 1 \right) = 37 \text{ cm}$$

$$\Rightarrow r \times \frac{37}{7} = 37 \text{ cm}$$

$$\Rightarrow r = 7 \text{ cm}$$

$$\therefore \text{Circumference of the circle} = 2\pi r = 2 \times \frac{22}{7} \times 7 \text{ cm} = 44 \text{ cm}$$

8. Correct answer: C

Common difference =

$$\frac{1 - 6q}{3q} - \frac{1}{3q} = \frac{1 - 6q - 1}{3q} = \frac{-6q}{3q} = -2$$

9. Given: ABCD be a parallelogram circumscribing a circle with centre O.

To prove: ABCD is a rhombus.

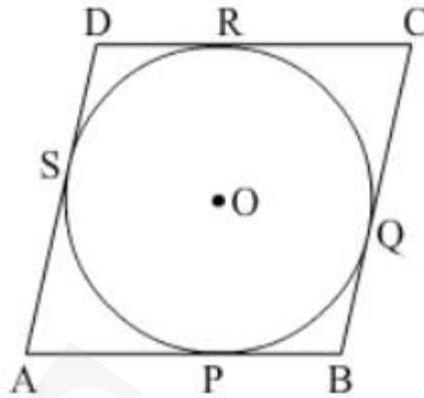

We know that the tangents drawn to a circle from an exterior point are equal in length.

Therefore, $AP = AS$, $BP = BQ$, $CR = CQ$ and $DR = DS$.

Adding the above equations,

$$AP + BP + CR + DR = AS + BQ + CQ + DS$$

$$(AP + BP) + (CR + DR) = (AS + DS) + (BQ + CQ)$$

$$AB + CD = AD + BC$$

$$2AB = 2BC$$

(Since, ABCD is a parallelogram so $AB = DC$ and $AD = BC$)

$$AB = BC$$

Therefore, $AB = BC = DC = AD$.

Hence, ABCD is a rhombus.

10. Dimension of the rectangular card board = 14 cm × 7 cm

Since, two circular pieces of equal radii and maximum area touching each other are cut from the rectangular card board, therefore, the diameter of each of each circular piece is $\frac{14}{2} = 7$ cm.

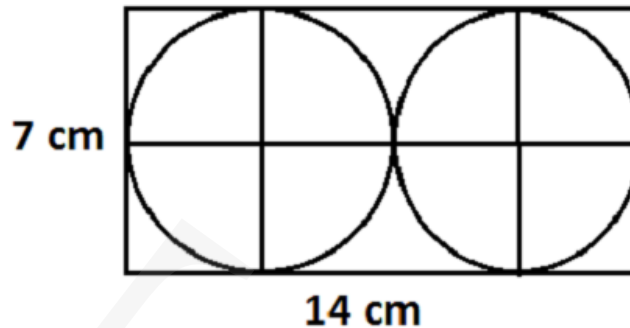

Radius of each circular piece = $\frac{7}{2}$ cm.

$$\therefore \text{Sum of area of two circular pieces} = 2 \times \pi \left(\frac{7}{2}\right)^2 = 2 \times \frac{22}{7} \times \frac{49}{4} = 77\text{cm}^2$$

Area of the remaining card board

= Area of the card board - Area of two circular pieces

$$= 14 \text{ cm} \times 7 \text{ cm} - 77 \text{ cm}^2$$

$$= 98 \text{ cm}^2 - 77 \text{ cm}^2$$

$$= 21 \text{ cm}^2$$

11. Given: AB = 12 cm, BC = 8 cm and AC = 10 cm.

Let, AD = AF = x cm, BD = BE = y cm and CE = CF = z cm

(Tangents drawn from an external point to the circle are equal in length)

$$\Rightarrow 2(x + y + z) = AB + BC + AC = AD + DB + BE + EC + AF + FC = 30 \text{ cm}$$

$$\Rightarrow x + y + z = 15 \text{ cm}$$

$$AB = AD + DB = x + y = 12 \text{ cm}$$

$$\therefore z = CF = 15 - 12 = 3 \text{ cm}$$

$$AC = AF + FC = x + z = 10 \text{ cm}$$

$$\therefore y = BE = 15 - 10 = 5 \text{ cm}$$

$$\therefore x = AD = x + y + z - z - y = 15 - 3 - 5 = 7 \text{ cm}$$

12. Three digit numbers divisible by 7 are

105, 112, 119, ... 994

This is an AP with first term (a) = 105 and common difference (d) = 7

Let a_n be the last term.

$$a_n = a + (n - 1)d$$

$$994 = 105 + (n - 1)(7)$$

$$7(n - 1) = 889$$

$$n - 1 = 127$$

$$n = 128$$

Thus, there are 128 three-digit natural numbers that are divisible by 7.

13.

$$4\sqrt{3}x^2 + 5x - 2\sqrt{3} = 0$$

$$\Rightarrow 4\sqrt{3}x^2 + 8x - 3x - 2\sqrt{3} = 0$$

$$\Rightarrow 4x \sqrt{3}x + 2 - \sqrt{3} \sqrt{3}x + 2 = 0$$

$$\Rightarrow 4x - \sqrt{3} \sqrt{3}x + 2 = 0$$

$$\therefore x = \frac{\sqrt{3}}{4} \text{ or } x = -\frac{2}{\sqrt{3}}$$

14. Let E be the event that the drawn card is neither a king nor a queen.

Total number of possible outcomes = 52

Total number of kings and queens = 4 + 4 = 8

Therefore, there are 52 - 8 = 44 cards that are neither king nor queen.

Total number of favourable outcomes = 44

$$\therefore \text{Required probability} = P(E) = \frac{\text{Favourable outcomes}}{\text{Total number of outcomes}} = \frac{44}{52} = \frac{11}{13}$$

15.

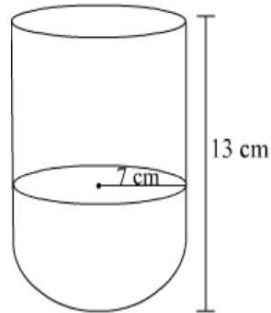

Let the radius and height of cylinder be r cm and h cm respectively.

Diameter of the hemispherical bowl = 14 cm

\therefore Radius of the hemispherical bowl = Radius of the cylinder

$$= r = \frac{14}{2} \text{ cm} = 7 \text{ cm}$$

Total height of the vessel = 13 cm

\therefore Height of the cylinder, $h = 13 \text{ cm} - 7 \text{ cm} = 6 \text{ cm}$

Total surface area of the vessel = 2 (curved surface area of the cylinder + curved surface area of the hemisphere)

(Since, the vessel is hollow)

$$= 2 \times 2\pi r h + 2\pi r^2 = 4\pi r h + 2\pi r^2 = 4 \times \frac{22}{7} \times 7 \times 6 + 2 \times \frac{22}{7} \times 7^2 \text{ cm}^2$$

$$= 1144 \text{ cm}^2$$

16.

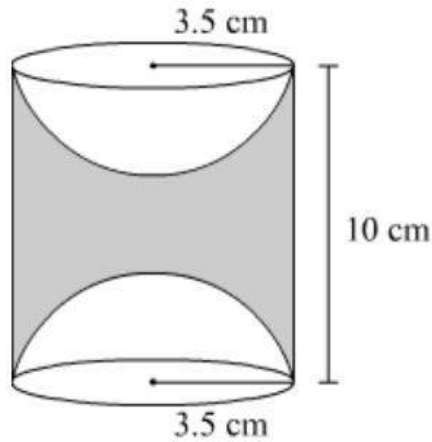

Height of the cylinder, $h = 10$ cm

Radius of the cylinder = Radius of each hemisphere = $r = 3.5$ cm

Volume of wood in the toy = Volume of the cylinder - $2 \times$ Volume of each hemisphere

$$\begin{aligned} &= \pi r^2 h - 2 \times \frac{2}{3} \pi r^3 \\ &= \pi r^2 \left(h - \frac{4}{3} r \right) \\ &= \frac{22}{7} \times (3.5)^2 \left(10 - \frac{4}{3} \times 3.5 \right) \\ &= 38.5 \times 10 - 4.67 \\ &= 38.5 \times 5.33 \\ &= 205.205 \text{ cm}^3 \end{aligned}$$

Radius = 21 cm

17. The arc subtends an angle of 60° at the centre.

$$\begin{aligned} \text{(i) } l &= \frac{\theta}{360^\circ} \times 2\pi r \\ &= \frac{60^\circ}{360^\circ} \times 2 \times \frac{22}{7} \times 21 \text{ cm} \\ &= 22 \text{ cm} \end{aligned}$$

$$\text{(ii) Area of the sector} = \frac{\theta}{360^\circ} \times \pi r^2$$

$$\begin{aligned} &= \frac{60^\circ}{360^\circ} \times \frac{22}{7} \times 21 \times 21 \text{cm}^2 \\ &= 231 \text{ cm}^2 \end{aligned}$$

18. AB and CD are the diameters of a circle with centre O.

\therefore OA = OB = OC = OD = 7 cm (Radius of the circle)

Area of the shaded region

= Area of the circle with diameter OB + (Area of the semi-circle ACDA - Area of \triangle ACD)

$$\begin{aligned} &= \pi \left(\frac{7}{2}\right)^2 + \left(\frac{1}{2} \times \pi \times 7^2 - \frac{1}{2} \times \text{CD} \times \text{OA}\right) \\ &= \frac{22}{7} \times \frac{49}{4} + \frac{1}{2} \times \frac{22}{7} \times 49 - \frac{1}{2} \times 14 \times 7 \\ &= \frac{77}{2} + 77 - 49 \\ &= 66.5 \text{ cm}^2 \end{aligned}$$

19. Let the y-axis divide the line segment joining the points (-4,-6) and (10,12) in the ratio k: 1 and the point of the intersection be (0,y).

Using section formula, we have:

$$\left(\frac{10k + -4}{k + 1}, \frac{12k + -6}{k + 1}\right) = 0, y$$

$$\therefore \frac{10k - 4}{k + 1} = 0 \Rightarrow 10k - 4 = 0$$

$$\Rightarrow k = \frac{4}{10} = \frac{2}{5}$$

Thus, the y-axis divides the

line segment joining the given points in the ratio 2:5

$$\therefore y = \frac{12k + -6}{k + 1} = \frac{12 \times \frac{2}{5} - 6}{\frac{2}{5} + 1} = \frac{\left(\frac{24 - 30}{5}\right)}{\left(\frac{2 + 5}{5}\right)} = -\frac{6}{7}$$

Thus, the coordinates of the point of division are $\left(0, -\frac{6}{7}\right)$.

20.

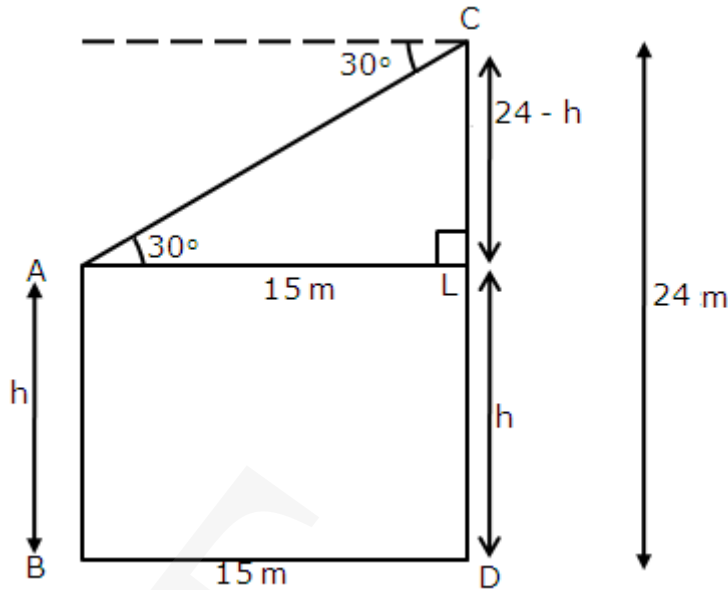

Let AB and CD be the two poles, where CD (the second pole) = 24 m.

$$BD = 15 \text{ m}$$

Let the height of pole AB be h m.

$$AL = BD = 15 \text{ m and } AB = LD = h$$

$$\text{So, } CL = CD - LD = 24 - h$$

In $\triangle ACL$,

$$\tan 30^\circ = \frac{CL}{AL}$$

$$\Rightarrow \tan 30^\circ = \frac{24 - h}{15}$$

$$\Rightarrow \frac{1}{\sqrt{3}} = \frac{24 - h}{15}$$

$$\Rightarrow 24 - h = \frac{15}{\sqrt{3}} = 5\sqrt{3}$$

$$\Rightarrow h = 24 - 5\sqrt{3}$$

$$\Rightarrow h = 24 - 5 \times 1.732 \quad [\text{Taking } \sqrt{3} = 1.732]$$

$$\Rightarrow h = 15.34$$

Thus, height of the first pole is 15.34 m.

$$21. (k + 4)x^2 + (k + 1)x + 1 = 0$$

$$a = k + 4, b = k + 1, c = 1$$

For equal roots, discriminant, $D = 0$

$$\Rightarrow b^2 - 4ac = 0$$

$$\Rightarrow (k + 1)^2 - 4(k + 4) \times 1 = 0$$

$$\Rightarrow k^2 + 2k + 1 - 4k - 16 = 0$$

$$\Rightarrow k^2 - 2k - 15 = 0$$

$$\Rightarrow k^2 - 5k + 3k - 15 = 0$$

$$\Rightarrow k(k - 5) + 3(k - 5) = 0$$

$$\Rightarrow (k - 5)(k + 3) = 0$$

$$\Rightarrow k = 5 \text{ or } k = -3$$

Thus, for $k = 5$ or $k = -3$, the given quadratic equation has equal roots.

$$22. S_n = 3n^2 + 4n$$

$$\text{First term } (a_1) = S_1 = 3(1)^2 + 4(1) = 7$$

$$S_2 = a_1 + a_2 = 3(2)^2 + 4(2) = 20$$

$$a_2 = 20 - a_1 = 20 - 7 = 13$$

$$\text{So, common difference } (d) = a_2 - a_1 = 13 - 7 = 6$$

$$\text{Now, } a_n = a + (n - 1)d$$

$$\therefore a_{25} = 7 + (25 - 1) \times 6 = 7 + 24 \times 6 = 7 + 144 = 151$$

23.

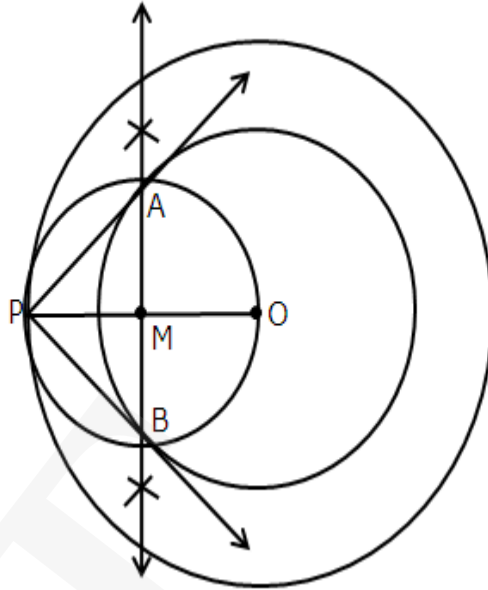

Steps of construction:

1. Draw two concentric circle with centre O and radii 4 cm and 6 cm. Take a point P on the outer circle and then join OP.
2. Draw the perpendicular bisector of OP. Let the bisector intersects OP at M.
3. With M as the centre and OM as the radius, draw a circle. Let it intersect the inner circle at A and B.
4. Join PA and PB.

Therefore, \overline{PA} and \overline{PB} are the required tangents.

24. The given points are A(-2,3) B(8,3) and C(6,7).

Using distance formula, we have:

$$AB^2 = 8 - (-2)^2 + 3 - 3^2$$

$$\Rightarrow AB^2 = 10^2 + 0$$

$$\Rightarrow AB^2 = 100$$

$$BC^2 = 6 - 8^2 + 7 - 3^2$$

$$\Rightarrow BC^2 = (-2)^2 + 4^2$$

$$\Rightarrow BC^2 = 4 + 16$$

$$\Rightarrow BC^2 = 20$$

$$CA^2 = -2 - 6^2 + 3 - 7^2$$

$$\Rightarrow CA = (-8)^2 + (-4)^2$$

$$\Rightarrow CA^2 = 64 + 16$$

$$\Rightarrow CA^2 = 80$$

It can be observed that:

$$BC^2 + CA^2 = 20 + 80 = 100 = AB^2$$

So, by the converse of Pythagoras Theorem,

$\triangle ABC$ is a right triangle right angled at C.

25. Diameter of circular end of pipe = 2 cm

$$\therefore \text{Radius } r_1 \text{ of circular end of pipe} = \frac{2}{200} \text{ m} = 0.01 \text{ m}$$

$$\text{Area of cross-section} = \pi \times r_1^2 = \pi \times 0.01^2 = 0.0001\pi \text{ m}^2$$

$$\text{Speed of water} = 0.4 \text{ m/s} = 0.4 \times 60 = 24 \text{ metre/min}$$

$$\text{Volume of water that flows in 1 minute from pipe} = 24 \times 0.0001\pi \text{ m}^3 = 0.0024\pi \text{ m}^3$$

$$\text{Volume of water that flows in 30 minutes from pipe} =$$

$$30 \times 0.0024\pi \text{ m}^3 = 0.072\pi \text{ m}^3$$

$$\text{Radius } (r_2) \text{ of base of cylindrical tank} = 40 \text{ cm} = 0.4 \text{ m}$$

Let the cylindrical tank be filled up to h m in 30 minutes.

Volume of water filled in tank in 30 minutes is equal to the volume of water flowed out in 30 minutes from the pipe.

$$\therefore \pi \times r_2^2 \times h = 0.072\pi$$

$$\Rightarrow 0.4^2 \times h = 0.072$$

$$\Rightarrow 0.16 h = 0.072$$

$$\Rightarrow h = \frac{0.072}{0.16}$$

$$\Rightarrow h = 0.45 \text{ m} = 45 \text{ cm}$$

Therefore, the rise in level of water in the tank in half an hour is 45 cm.

26. The group consists of 12 persons.

\therefore Total number of possible outcomes = 12

Let A denote event of selecting persons who are extremely patient

\therefore Number of outcomes favourable to A is 3.

Let B denote event of selecting persons who are extremely kind or honest.

Number of persons who are extremely honest is 6.

Number of persons who are extremely kind is $12 - (6 + 3) = 3$

\therefore Number of outcomes favourable to B = $6 + 3 = 9$.

(i)

$$P(A) = \frac{\text{Number of outcomes favourable to A}}{\text{Total number of possible outcomes}} = \frac{3}{12} = \frac{1}{4}$$

(ii)

$$P(B) = \frac{\text{Number of outcomes favorable to B}}{\text{Total number of possible outcomes}} = \frac{9}{12} = \frac{3}{4}$$

Each of the three values, patience, honesty and kindness is important in one's life.

27. Diameter of upper end of bucket = 30 cm

\therefore Radius (r_1) of upper end of bucket = 15 cm

Diameter of lower end of bucket = 10 cm

\therefore Radius (r_2) of lower end of bucket = 5 cm

Slant height (l) of frustum

$$\begin{aligned} &= \sqrt{r_1 - r_2^2 + h^2} \\ &= \sqrt{15 - 5^2 + 24^2} = \sqrt{10^2 + 24^2} = \sqrt{100 + 576} \\ &= \sqrt{676} = 26\text{cm} \end{aligned}$$

Area of metal sheet used to make the bucket

$$\begin{aligned} &= \pi r_1 + r_2 l + \pi r_2^2 \\ &= \pi 15 + 5 \cdot 26 + \pi 5^2 \\ &= 520\pi + 25\pi = 545\pi\text{cm}^2 \end{aligned}$$

Cost of 100 cm² metal sheet = Rs 10

Cost of 545 π cm² metal sheet

$$= \text{Rs. } \frac{545 \times 3.14 \times 10}{100} = \text{Rs. } 171.13$$

Therefore, cost of metal sheet used to make the bucket is Rs 171.13.

28. Given: l and m are two parallel tangents to the circle with centre O touching the circle at A and B respectively. DE is a tangent at the point C , which intersects l at D and m at E .

To prove: $\angle DOE = 90^\circ$

Construction: Join OC .

Proof:

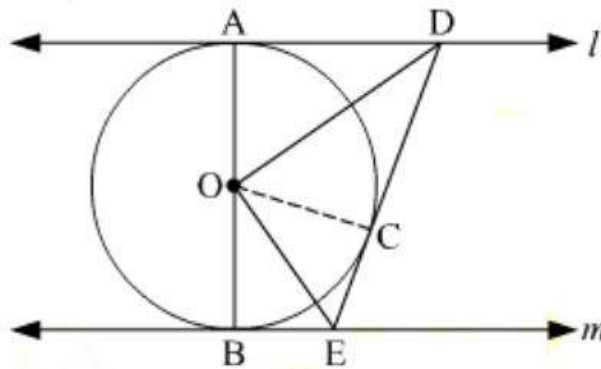

In $\triangle ODA$ and $\triangle ODC$,

$OA = OC$ (Radii of the same circle)

$AD = DC$ (Length of tangents drawn from an external point to a circle are equal)

$DO = OD$ (Common side)

$\triangle ODA \cong \triangle ODC$ (SSS congruence criterion)

$$\therefore \angle DOA = \angle COD \quad \dots (1)$$

Similarly, $\triangle OEB \cong \triangle OEC$

$$\therefore \angle EOB = \angle COE \quad \dots (2)$$

Now, AOB is a diameter of the circle. Hence, it is a straight line.

$$\angle DOA + \angle COD + \angle COE + \angle EOB = 180^\circ$$

From (1) and (2), we have:

$$2\angle COD + 2\angle COE = 180^\circ$$

$$\Rightarrow \angle COD + \angle COE = 90^\circ$$

$$\Rightarrow \angle DOE = 90^\circ$$

Hence, proved.

29. Let the sides of the two squares be x cm and y cm where $x > y$.

Then, their areas are x^2 and y^2 and their perimeters are $4x$ and $4y$.

By the given condition:

$$x^2 + y^2 = 400 \quad \dots (1)$$

$$\text{and } 4x - 4y = 16$$

$$\Rightarrow 4(x - y) = 16 \Rightarrow x - y = 4$$

$$\Rightarrow x = y + 4 \quad \dots (2)$$

Substituting the value of x from (2) in (1), we get:

$$(y + 4)^2 + y^2 = 400$$

$$\Rightarrow y^2 + 16 + 8y + y^2 = 400$$

$$\Rightarrow 2y^2 + 16 + 8y = 400$$

$$\Rightarrow y^2 + 4y - 192 = 0$$

$$\Rightarrow y^2 + 16y - 12y - 192 = 0$$

$$\Rightarrow y(y + 16) - 12(y + 16) = 0$$

$$\Rightarrow (y + 16)(y - 12) = 0$$

$$\Rightarrow y = -16 \text{ or } y = 12$$

Since, y cannot be negative, $y = 12$.

$$\text{So, } x = y + 4 = 12 + 4 = 16$$

Thus, the sides of the two squares are 16 cm and 12 cm.

30.

$$\frac{1}{2a + b + 2x} = \frac{1}{2a} + \frac{1}{b} + \frac{1}{2x}$$

$$\Rightarrow \frac{1}{2a + b + 2x} - \frac{1}{2x} = \frac{1}{2a} + \frac{1}{b}$$

$$\Rightarrow \frac{2x - 2a - b - 2x}{2x(2a + b + 2x)} = \frac{b + 2a}{2ab}$$

$$\Rightarrow \frac{-2a + b}{2x(2a + b + 2x)} = \frac{b + 2a}{2ab}$$

$$\Rightarrow \frac{-1}{x(2a + b + 2x)} = \frac{1}{ab}$$

$$\Rightarrow 2x^2 + 2ax + bx + ab = 0$$

$$\Rightarrow 2x(x + a) + b(x + a) = 0$$

$$\Rightarrow (x + a)(2x + b) = 0$$

$$\Rightarrow x + a = 0 \text{ or } 2x + b = 0$$

$$\Rightarrow x = -a, \text{ or } x = \frac{-b}{2}$$

31.

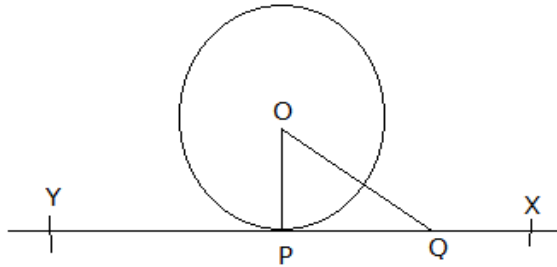

Given: A circle with centre O and a tangent XY to the circle at a point P

To Prove: OP is perpendicular to XY.

Construction: Take a point Q on XY other than P and join OQ.

Proof: Here the point Q must lie outside the circle as if it lies inside the tangent XY will become secant to the circle.

Therefore, OQ is longer than the radius OP of the circle, That is, $OQ > OP$. This happens for every point on the line XY except the point P.

So OP is the shortest of all the distances of the point O to the points on XY.

And hence OP is perpendicular to XY.

Hence, proved.

32. Given AP is -12, -9, -6, ..., 21

First term, $a = -12$

Common difference, $d = 3$

Let 21 be the n^{th} term of the A.P.

$$21 = a + (n - 1)d$$

$$\Rightarrow 21 = -12 + (n - 1) \times 3$$

$$\Rightarrow 33 = (n - 1) \times 3$$

$$\Rightarrow n = 12$$

Sum of the terms of the AP = S_{12}

$$= \frac{n}{2} [2a + (n - 1)d] = \frac{12}{2} [-24 + 11 \times 3] = 54$$

If 1 is added to each term of the AP, the sum of all the terms of the new AP will increase by n , i.e., 12.

$$\therefore \text{Sum of all the terms of the new AP} = 54 + 12 = 66$$

33. Let AC and BD be the two poles of the same height h m.

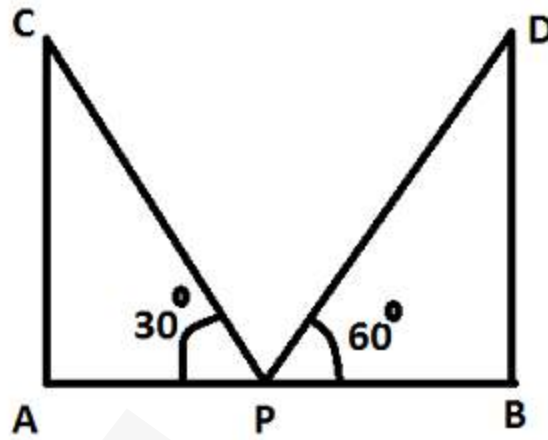

Given $AB = 80$ m

Let $AP = x$ m, therefore, $PB = (80 - x)$ m

In $\triangle APC$,

$$\tan 30^\circ = \frac{AC}{AP}$$
$$\frac{1}{\sqrt{3}} = \frac{h}{x} \quad \dots (1)$$

In $\triangle BPD$,

$$\tan 60^\circ = \frac{BD}{PB}$$
$$\sqrt{3} = \frac{h}{80 - x} \quad \dots (2)$$

Dividing (1) by (2),

$$\frac{\frac{1}{\sqrt{3}}}{\frac{1}{\sqrt{3}}} = \frac{\frac{h}{x}}{\frac{h}{80-x}}$$
$$\Rightarrow \frac{1}{3} = \frac{80-x}{x}$$
$$\Rightarrow x = 240 - 3x$$
$$\Rightarrow 4x = 240$$
$$\Rightarrow x = 60$$

From (1),

$$\frac{1}{\sqrt{3}} = \frac{h}{x}$$
$$\Rightarrow h = \frac{60}{\sqrt{3}} = 20\sqrt{3}\text{m}$$

Thus, the height of both the poles is $20\sqrt{3}\text{m}$ and the distances of the point from the poles are 60 m and 20 m.

34. The given vertices are $A(x,y)$, $B(1,2)$ and $C(2,1)$.

It is known that the area of a triangle whose vertices are (x_1, y_1) , (x_2, y_2) and (x_3, y_3) is given by

$$\frac{1}{2} |x_1 y_2 - y_3 + x_2 y_3 - y_1 + x_3 y_1 - y_2|$$

\therefore Area of $\triangle ABC$

$$= \frac{1}{2} |x \cdot 2 - 1 + 1 \times 1 - y + 2 \cdot y - 2|$$
$$= \frac{1}{2} |x + 1 - y + 2y - 4|$$
$$= \frac{1}{2} |x + y - 3|$$

The area of $\triangle ABC$ is given as 6 sq units.

$$\Rightarrow \frac{1}{2} [x + y - 3] = 6 \Rightarrow x + y - 3 = 12$$
$$\therefore x + y = 15$$